

LEGEND®

Pressure Side Pool Cleaner



Installation Guide

IMPORTANT SAFETY INSTRUCTIONS
READ AND FOLLOW ALL INSTRUCTIONS
SAVE THESE INSTRUCTIONS

Customer Service

If you have questions about ordering Pentair replacement parts, and pool products, please use the following contact information:

Customer Service (8 A.M. to 5 P.M. — Eastern and Pacific Times)

Phone: (800) 831-7133

Fax: (800) 284-4151

Technical Support

Sanford, North Carolina (8 A.M. to 5 P.M. — Eastern Time)

Phone: (919) 566-8000

Fax: (919) 566-8920

Moorpark, California (8 A.M. to 5 P.M. — Pacific Time)

Phone: (805) 553-5000 (Ext. 5591)

Fax: (805) 553-5515

Web site

visit www.pentairpool.com and www.staritepool.com to find information about our products

© 2007 Pentair Water Pool and Spa, Inc. All rights reserved.

This document is subject to change without notice.

1620 Hawkins Ave., Sanford, NC 27330 • (800) 831-7133 • (919) 566-8000

10951 West Los Angeles Ave., Moorpark, CA 93021 • (800) 831-7133 • (805) 553-5000

Trademarks and Disclaimers. Pentair Water Pool and Spa and Legend are trademarks and/or registered trademarks of Pentair Water Pool and Spa, Inc. Other trademarks and trade names may be used in this document to refer to either the entities claiming the marks and names or their products. Pentair Water Pool and Spa, Inc. disclaims any proprietary interest in trademarks and trade names other than its own.

LEGEND[®]

LL105G

LL105W

Important Information:

The Legend[®] automatic pool cleaner comes ready to connect into a female threaded 1-1/2" line, dedicated to our Universal Booster Pump. Also, if you have a chlorinator, solar system or other air inducing equipment, please contact our Technical Support Department at 1-800-831-7133, before you install the Legend[®]. (See diagram on page 2.)

The following are important facts to remember before installing and operating the Legend[®].

1. Always disconnect the Legend[®] from the pool wall when cleaning or back washing the pool filter.
2. After cleaning or back washing, let the filtration system run for at least five minutes before reconnecting the Legend[®].
3. New plumbing lines should be flushed out before installing the Legend[®].
4. The Legend[®] should not be used to remove plaster dust in new pools.
5. Always remove the Legend[®] before swimmers enter the pool.
6. Always handle the Legend[®] with care. Do not let children or pets play with the unit: it is not a toy.
7. Always pick up the Legend[®] by the Vacuum Tube, especially when lifting the unit out of the water.
8. Unless checking the wheel RPM, do not handle the Legend[®] while it is operating.
9. Always remove the Legend[®] from the pool before chemical shock treatments. As a rule, any pool water that is unsafe for swimming is unsafe for the Legend[®].
10. Carefully cut the feed hose following the instructions on Page 3.

By following these simple guidelines, you can help protect against injury and prolong the life of your Legend[®].

Before the Legend[®] is installed, please take a moment to record the serial number. This number is located on your warranty card and on the back of the Legend[®] near the rear jet. You will be asked for this number when you contact our Technical Support Department.

SERIAL # _____

TABLE OF CONTENTS

I. Introduction	1
A. Thank You for Choosing the Legend®	1
B. What to Expect from the Legend®	1
II. Installation Instructions	2
A. Legend® Components	2
B. Pool Connections	2
C. Booster Pump Installation	2
D. Installing the Twist Lock Pressure Relief Valve (Wall Fitting)	3
E. Cutting the Feed Hose	3
F. Checking Operation	7
G. Fine Tuning the Legend®	7
1. Thrust Jet Adjustment	7
2. Sweep Hose Adjustment	7
3. Checking Wheel RPM	8
III. Operation & Periodic Maintenance	9
A. Connecting/Disconnecting the Legend®	9
B. Turning the Legend® On/Off	9
C. Cleaning the Sand & Silt Bag	9
D. Periodic Maintenance	9
1. Wall Fitting Screen	9
2. Tires & Bearings	10
3. Roller Rings	10
4. Debris Bags	10
5. Sweep Hose	10
6. Debris Valve	10
E. Back Washing the Pool Filter	10
F. Storage and Winterizing	10
G. Accessories	10
1. Sweep Hose Weight	10
2. Leaf Bag	11
3. Step Adapter	11
4. Suction Cup Tires	11
IV. Troubleshooting	12
Legend® Parts List	13
Legend® Exploded View	15

I. Introduction

A. Thank You for Choosing the Legend® Pool Cleaner

Congratulations on the purchase of your new automatic pool cleaner. The Legend® is designed to give you years of dependable and efficient service. With the Legend®, you and your family will spend more time relaxing and enjoying your pool and less time cleaning it.

The Legend® has been designed and built with time proven features and patented innovations to create an automatic pool cleaner that will give you years of dependable service. The Legend® is built with pride by people who care about the product using state of the art materials and backed by a limited warranty that protects against defects in parts and construction.

Like any mechanical device, the Legend® requires some preventative maintenance and the replacement of certain hard working parts. We recommend that you have your Legend® checked annually. For best results have your Legend® installed by a qualified swimming pool professional.

For pool owners with plumbing and mechanical experience, installation instructions are included in this manual.

Please put safety first! Be sure to take your Legend® out of your pool and store it carefully in a shaded area before anyone enters the pool.

B. What to Expect from the Legend®

When operating correctly, the Legend® will travel randomly throughout the pool, vacuuming and sweeping the bottom. The climbing ability of the Legend® is dependent on the pools shape. It will climb better in pools without sharp angles or curves in the transition from the pool floor to the pool wall.

The Legend® comes equipped with a Wall Fitting (Part# EW22) that features a Twist Lock Automatic Pressure Relief Valve. If the Legend® is receiving too much water pressure to the unit, the relief valve will automatically reduce water pressure.

Approximately every three minutes and 30 seconds the Legend® will go into a back up mode. At this time the Back Up Valve will pull the Legend® away from problem areas.

Occasionally some vinyl pools have steps installed so the unit may not climb and remains stationary until the Back Up Valve pulls the unit away from the steps. When this occurs you need to use the optional Step Adapter (Part# EU13) to prevent wearing the vinyl liner.

The Sweep Hose operates in a gentle sweeping motion to prevent debris from becoming trapped in hard to reach corners of the pool.

II. Installation Instructions

A. Legend® Components

The Legend® Box Contains:

1. Cleaner Head
2. Sand & Silt Bag
3. Sweep Hose
4. Complete Feed Hose
 - a. 1 - 8½" hose
 - b. 2 - 10' white (hard) hoses
 - c. 1 - 30" clear (soft) hose / 1 - 7.5' clear (soft) hose
 - d. 10 - Floats
 - e. 3 - Swivels
 - f. 1 - Back-up Valve
 - g. 10 - Mender Nuts
 - h. 1 - Wall Fitting Complete

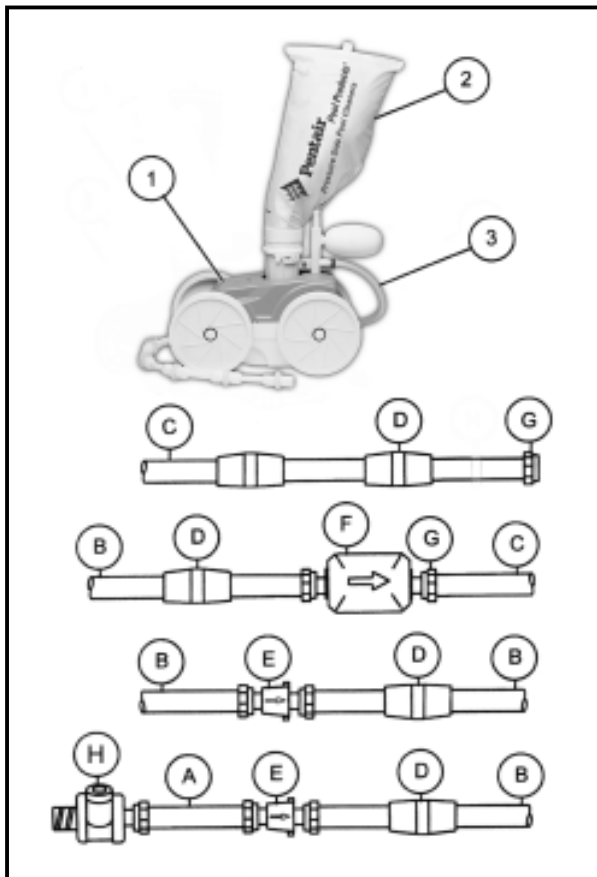

B. Pool Connections

The Legend® comes equipped to connect to a female threaded 1-1/2" line, dedicated to our Universal Booster Pump.

Also, if the pool doesn't have a dedicated cleaner line, please contact our Technical Support Department at 1-800-831-7133.

C. Booster Pump Installation

If you already have a 3/4 horsepower booster pump installed at your equipment pad and it is operational, skip this section and proceed to Installing the Twist Lock Pressure Relief Valve (Wall Fitting).

Detailed booster pump installation instructions are packaged separately in our booster pump box. **Please follow these instructions carefully.**

The booster pump is not self-priming and needs to be fed with water taken from the pool filter before any type of in-line chlorinator. See figure below.

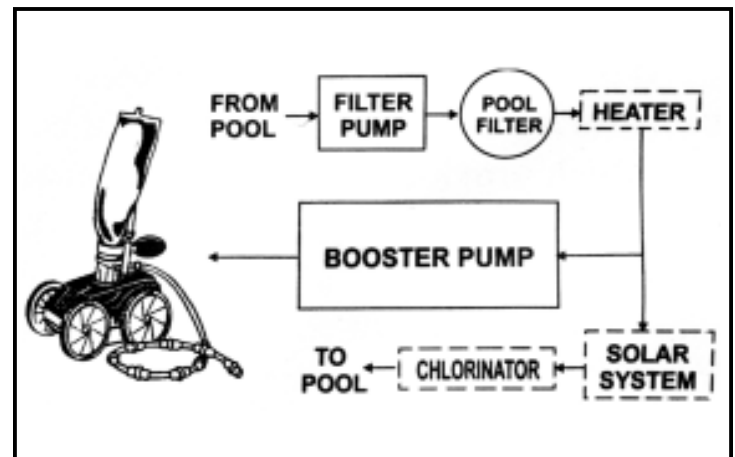

D. Installing the Twist Lock Pressure Relief Valve (Wall Fitting)

1. Take out any existing pool cleaner and/or wall fitting.
2. Turn on the filtration pump and booster pump, flush out the plumbing line.
3. Turn off filter pump and booster pump.
4. Remove the Wall Adapter from the Wall Fitting and screw Adapter by hand into the dedicated line. Turn until tight.

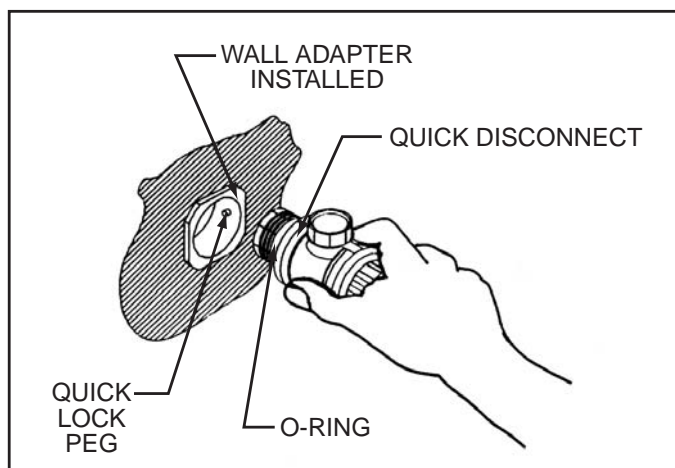

5. Take the Wall Fitting and Twist Lock the Wall Fitting into the Wall Adapter 1/4 turn and pull out; to a snug fit. Once the Wall Adapter is secure, you can now twist lock and unlock to remove Wall Fitting with ease from the Wall Adapter.

E. Cutting the Feed Hose (See Hose Diagrams on Page 4)

The Hose assembly comes in 5 sections now covering approximately 30 ft. of the pool, which provides ample hose for most residential pools. The Back-Up Valve is now 30" from the head cleaner and should always remain this distance. For larger pools, see **#14 on page 6** for instructions on *Adding Additional Feeder Hose*.

1. Take Feeder Hose out of box (it will be approximately 30 feet long). Before installing the unit, you should lay the feed hose out straight in the sun, (for one day if possible). The hose has been curled up in the box and sometimes will go around in a circle. If this happens, take the first or second section of hose from the wall and reverse it, (turn it around). You might have to reverse both sections to correct the problem. Make sure the feed hose is cut and installed properly.
2. Measure how deep your pool is by using your telepole or the clear end of the feeder hose. Cut the clear (soft) hose equal to the depth of your pool. (Hint: the grate or domed main drain at the bottom is usually the deepest point.)

Example: The clear (soft) hose is 10 ft. long, if the pool is 8½ ft. deep, cut 1½ ft. off of the clear (soft) hose. If the depth is greater than 10 ft., do not cut the clear (soft) hose.

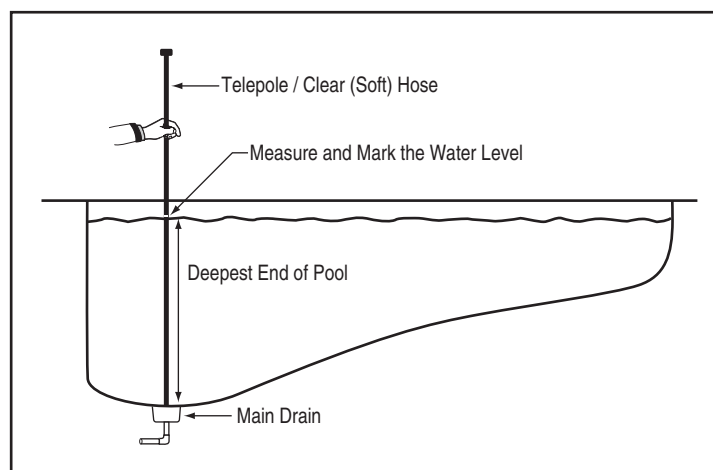

EXAMPLE OF HOSE ASSEMBLY BEFORE CUTTING TO LENGTH

STEPS

1. With the feed hose assembly attached to the pool wall, hold the feed hose assembly by the opposite end with the clear hose and walk the perimeter of the pool to locate the farthest point on the perimeter from the wall fitting without stretching the hose assembly.
2. Measure the distance that the hose assembly extends beyond the pool perimeter farthest point located in **Step 1** — (7½ ft. in this example).
3. Cut half of the length obtained from **Step 2** — (3¾ ft. in this example), equally from each of the 10 foot lengths of white or grey hose on either side of the marked swivel.

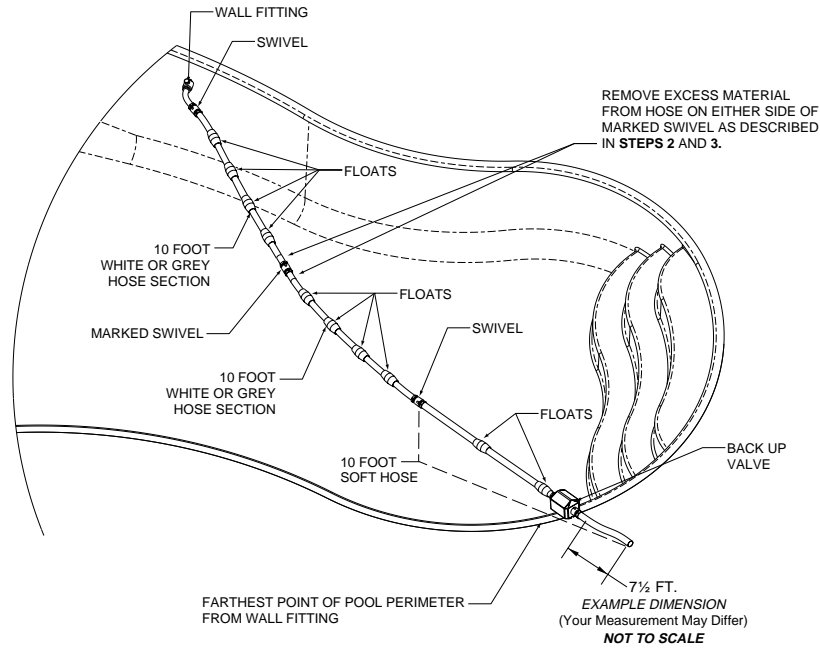

EXAMPLE OF FINISHED HOSE ASSEMBLY AFTER CUTTING TO LENGTH

STEPS

4. Reassemble the hoses using the supplied mender nuts as shown in **FIGURE 1**.
5. Your complete finished hose assembly should look like this. The end of the 30 inch clear hose should reach just to the furthest edge of the pool perimeter as shown.

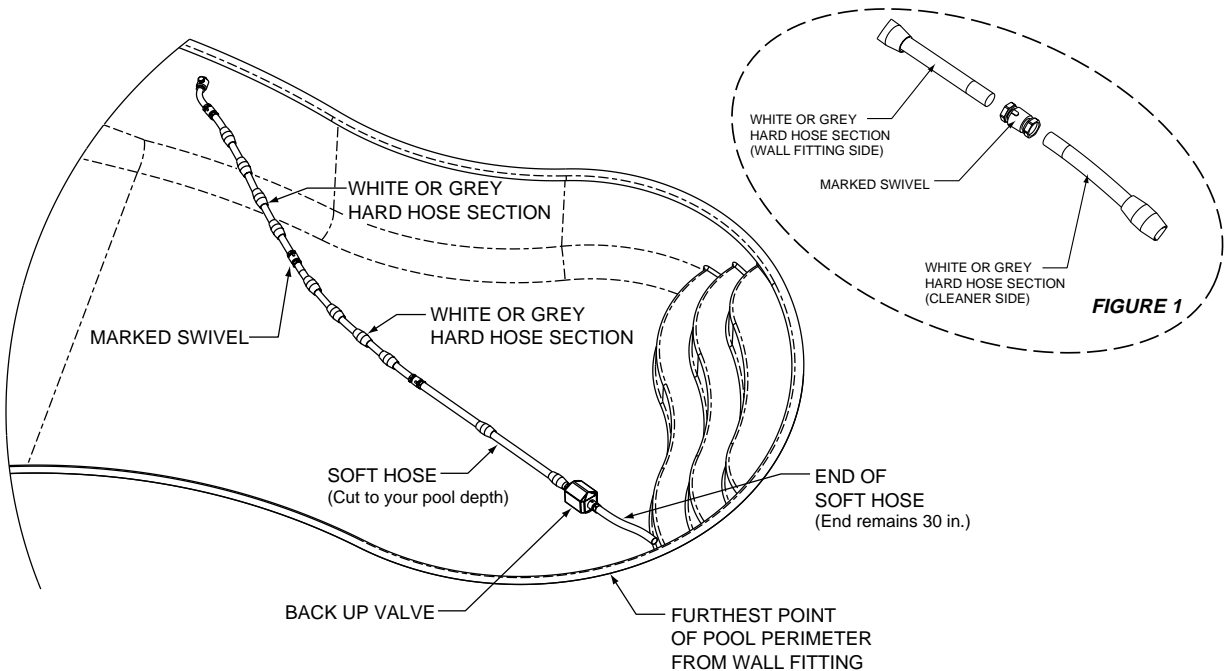

E. Cutting the Feed Hose - (cont.)

- Lay the telepole next to the clear (soft) hose. If the clear (soft) hose is longer than the mark on the telepole, cut the excess from the end attached to the white (hard) hose. Do not cut off the float. Leave the first float in position next to the Back-Up Valve. Place the second float midway between the first float and the Hose Swivel.

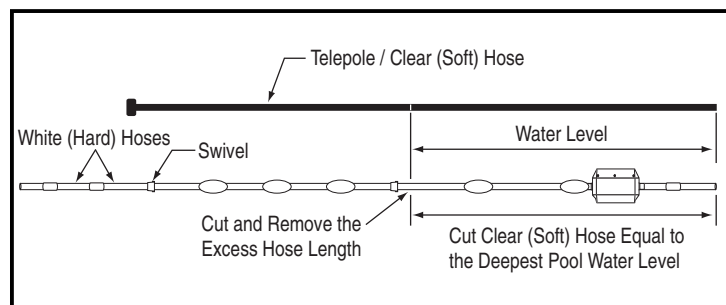

- Attach feed hose to the wall fitting and attach wall fitting to the pool wall. Hold the end of clear (soft) hose and walk the perimeter of the pool keeping the hose straight (do not stretch hose) to find the farthest point of the pool from the wall fitting.
- Measure the excess length between the farthest point of the pool from Wall Fitting and the end of 30 in. clear (soft) hose.
- Half of this measured length is to be **cut equally from 10 ft. white (hard) hoses next to the Marked Swivel**. (Example: Half of 6 ft. = 3 ft. each). If you are cutting more than 2 ft. off the hoses, remove the floats next to the Marked Swivel from both hoses. See figures on [page 4](#).

- Re-assemble the hoses and the swivel using mender nuts, see the Figure below. Put mender nut on swivels first, then push hose over swivel, rotate mender nut over hose clockwise until tight. *Note: Keep as many floats as possible on white feed hoses spaced evenly apart to hold hose up on top of water.*

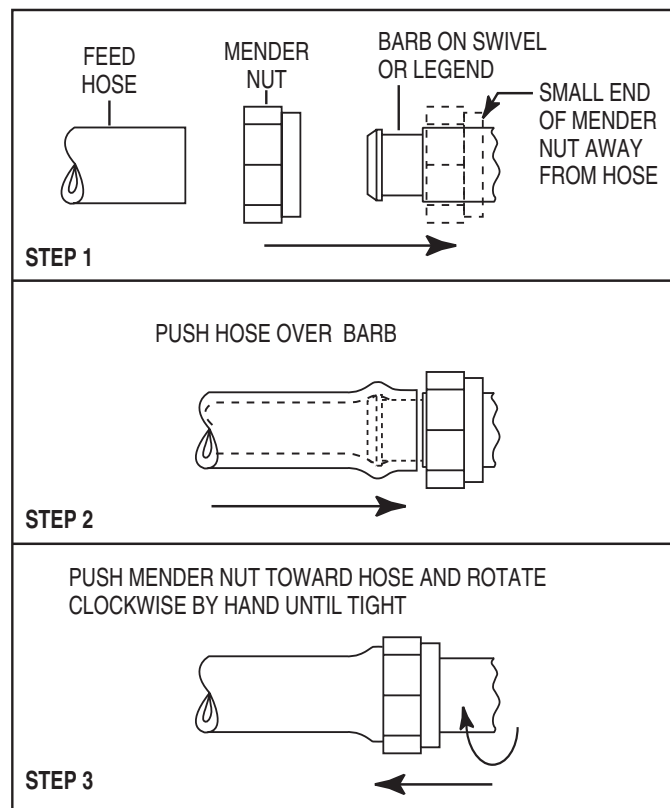

E. Cutting the Feed Hose - (cont.)

8. When cutting hoses, please use strong scissors or a sharp knife. Be sure to slide the floats out of the way when cutting hose.
9. Put extra mender nut on the Legend® mast and push clear (soft) hose gently over mast at 1/2", turn mender nut around clear (soft) hose tight. **Note:** The Back-Up Valve still should be 30" from the head of the cleaner.

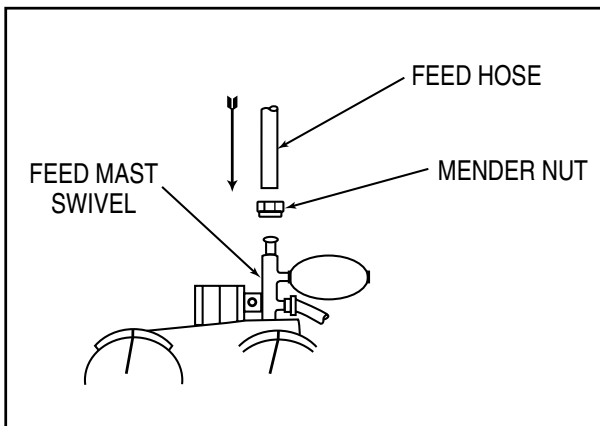

10. Now take the bag, EU16, out of the box and firmly twist lock bag onto the top of Legend® throat over rubber debris valve.
11. Review and check list: White and clear hoses cut properly and floats evenly spaced. Mender nuts tight around swivels, Back-Up Valve, Legend® mast and wall fitting. Make sure wall fitting is securely locked into place.

12. Lower your complete Legend® assembly into your pool carefully. It should look like figure below.

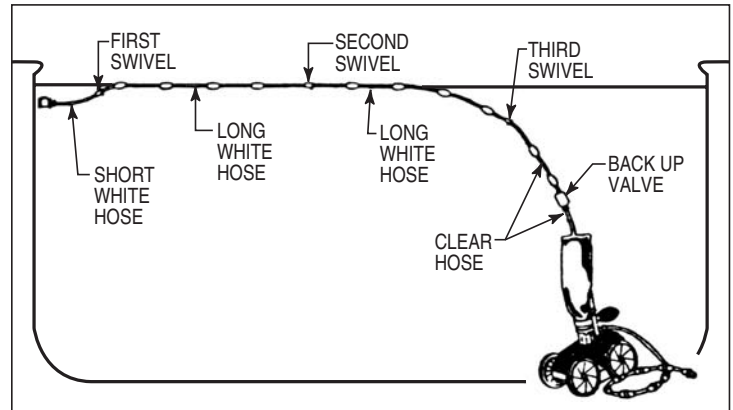

13. Go back to your equipment and turn filter pump on first (wait 30 seconds to force air out of the hose), then turn booster pump on.
14. For adding additional feeder hose for large pools requiring more hose length you will need to purchase one (1) additional hose (LLD45), four (4) floats (ED10P), one (1) swivel (ED05), and two (2) mender nuts (ED15). Attach extra white (hard) hose between clear (soft) hose and existing white (hard) hose, using floats, swivel and mender nuts. Divide extra white (hard) hose overage by three (3) this time to keep all white the same length.

F. Checking Operation

When operating correctly, the Legend® will travel in a random pattern throughout the pool, vacuuming and sweeping the bottom. The climbing ability of the Legend® is dependent on the pools structure and water flow coming into the pool. It will perform more efficiently in pools without sharp angles or curves in the transition from the floor of the pool to the wall.

The Legend® comes with a Twist Lock Pressure Relief Valve (Wall Fitting). If the Legend® is receiving too much water pressure, the Relief Valve in the Wall Fitting will release the excess water pressure.

Approximately every three minutes and 30 seconds the Legend® will go into a back-up mode. The Back-Up Valve cycle time, while in the back-up mode, is approximately 30 seconds, pulling the Legend® from problem areas.

New Back-Up Valve Information:

The Back-Up Valve Insert (#MBUVP) which slides into the slot over the jet of the valve. This is secured with a stainless steel screw (#VX-9) as shown in the diagram. The insert will be set from the factory with the larger (3/8") hole over the opening of the jet. The larger hole is used for the Legend® cleaner. If you change the insert to the smaller (1/4") hole, the Back-Up Valve will have increased jet pressure and possibly tangle your hose.

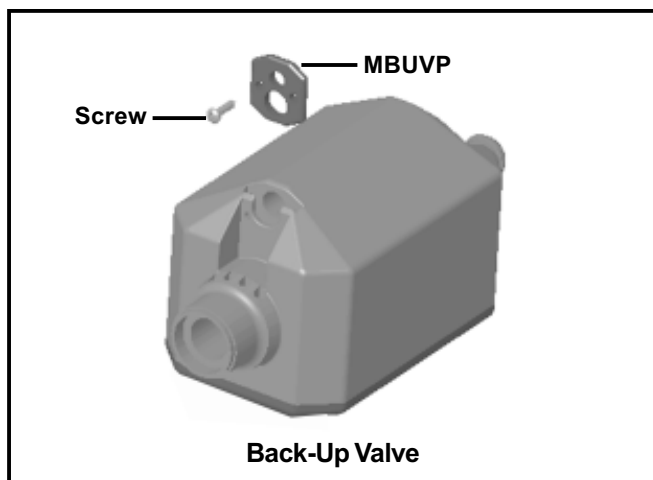

The Sweep Hose operates in a gentle sweeping motion to prevent debris from becoming trapped in hard to reach corners of the pools.

If the Legend® does not travel to all areas of the pool, turn off the booster pump and pool filtration pump and make the necessary adjustments from the instructions in the next section.

G. Fine Tuning the Legend®

1. Thrust Jet Adjustment

There is a Thrust Jet located in the back of the Legend®. This Thrust Jet alters the direction of the cleaner. The factory standard position for the jet is set in the middle and straight out. (See illustration below.)

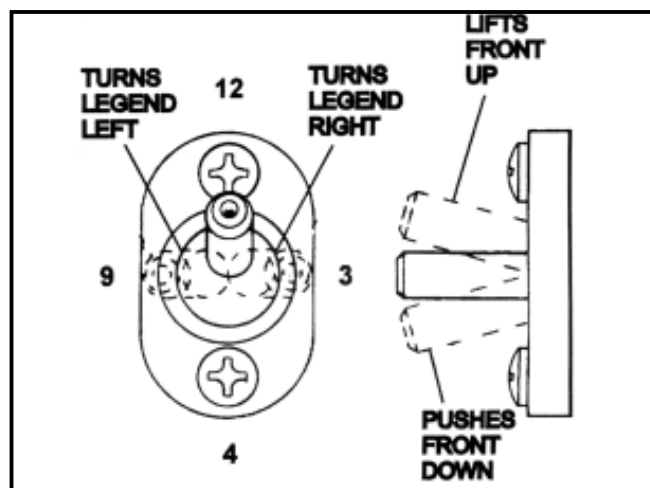

2. Sweep Hose Adjustment

The Sweep Hose operates in a gentle sweeping motion. To increase or decrease the motion of the Sweep Hose, adjust the screw which is located on the Feed Mast Barb below the Ballast Float. Turning the screw clockwise will decrease the motion and counter-clockwise to increase the motion of the Sweep Hose.

G. Fine Tuning the Legend®

3. Checking Wheel RPM

To determine whether the Legend® is receiving the proper water pressure, turn off the pool pump, and carefully remove the Legend® from the pool.

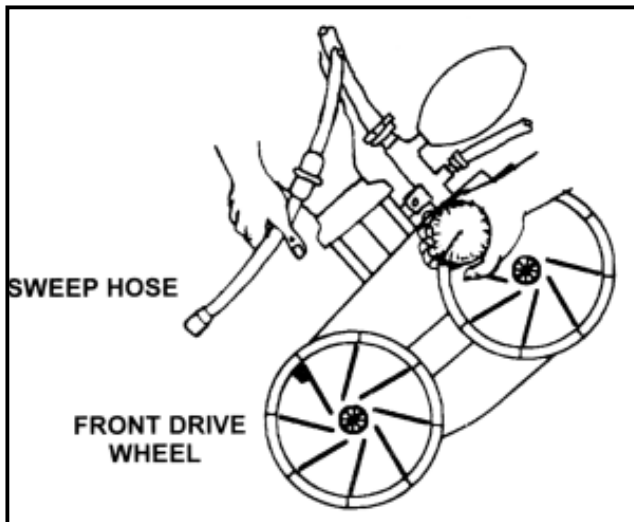

Mark the front drive Tire/Wheel with a marker, or use the Pentair logo located on the side of tire as a marker to count the rotations of the wheel per minute.

Have someone turn on pool pump and the booster pump while you place the Legend® in the pool just beneath the water surface. (Be sure to hold onto the Sweep Hose to avoid getting wet).

Count the rotations of the marked wheel for exactly one minute. (Be sure the Back-Up Valve isn't cycling at this time). The rotations will give you the Revolutions Per Minute. (RPM)

For proper performance, the Legend® operates between 28-32 RPM. If the RPM is below 28 then call your local Pool Professional or contact our Technical Support Department at 1-800-831-7133.

If the RPM is more than 32, at the Wall Fitting, unscrew the Pressure Relief Valve slowly until the RPM falls between 28-32.



If you have any additional questions, please contact Pentair Pool Products Inc., Technical Support Department at: 1-800-831-7133, Monday through Friday.

III. Operation/Periodic Maintenance

A. Connecting/Disconnecting the Legend®

Turn off the booster pump and pool pump. Then take the Wall Fitting and twist lock the Wall Fitting clockwise into the Wall Adapter. To disconnect the Legend®, unlock and twist counter-clockwise. The Wall Adapter should remain in the pool wall.

B. Turning On/Off the Legend®

The Legend® operates off the booster pump coming from the equipment pad, and can be turned on or off by merely turning on/off your booster pump time clock.

C. Cleaning the Sand & Silt Bag

Carefully unlock the debris bag from the vacuum tube and open the Velcro® Brand fastener at the top of debris bag and dump debris.

If you have a lot of debris in your pool, especially after a storm, you can run your Legend® in two shorter cycles per day and empty the debris bag between cycles.

Reconnect the debris bag to the vacuum tube. Do NOT over turn.

If the Velcro® Brand fastener strip on top of the debris bag does not stay secure, rinse well, let it dry and clean with a stiff brush.

A Helpful Hint: It is easier to empty the debris bag when it is dry. A second bag may be used while the full debris bag is drying.

It's best to empty the debris bag when it becomes half full. The Legend® will have better performance if the bag is not overloaded.

D. Periodic Maintenance

The following parts are wear items that should be checked, maintained or replaced as needed. Wear items are considered any working or moving part(s) being worn due to the use of the cleaner. **Wear items are not covered under warranty.**

1. Wall Fitting Screen

Inside the wall fitting is a filter screen that acts as a secondary filter. This screen is to keep debris that is passed by the pool filter out of the Legend®. *Running the Cleaner without the filter screen can damage the Legend® and will void the warranty.*

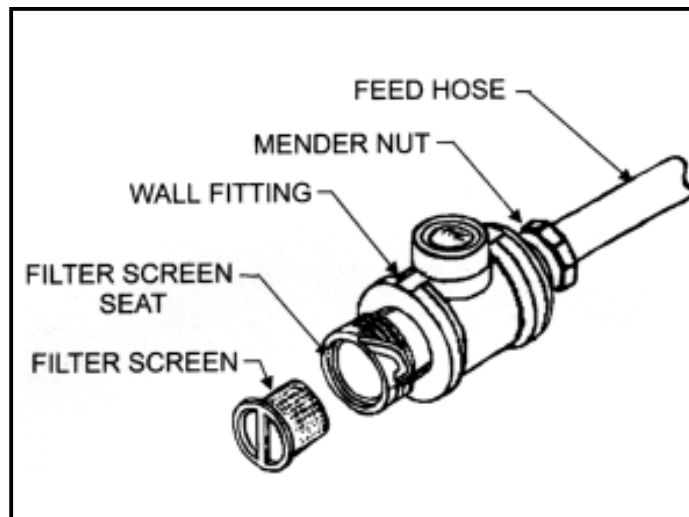

A continuous plugged or dirty screen is a sign of problems in your pool filtration system and you need to contact your local Pool Professional.

To clean the filter screen, pull the screen out from inside the Wall Fitting and rinse thoroughly and push back inside the Wall Fitting.

Whenever cleaning, back-washing or repairing the filter, remove the Wall Fitting and flush out the dedicated line before using the Legend®.

III. Operation/Periodic Maintenance - (cont.)

2. Tires & Bearings

The tires are designed to protect the bottom of your pool and provide better traction. You need to rotate or replace the tires when edges become rounded.

The Wheel Bearings are warranted free of defects when shipped from Pentair Water Pool and Spa, Inc., and are considered a wear item. A good bearing will spin freely.

3. Roller Rings

Your Sweep Hose has a series of Roller Rings to protect the Sweep Hose. Replace the rings as needed. You can rotate the Roller Rings to prevent flat spots.

4. Debris Bags

Fine Mesh Sand & Silt Bag

The Legend® comes with a Sand & Silt bag for general use in all pools. We do not recommend using the fine mesh bag to pick up leaves and twigs or other large debris for they have sharp points and edges that can poke holes and eventually rip the bag.

Optional Leaf Bag

The leaf bag is a larger mesh bag made to pick up heavier debris such as leaves, twigs, acorns, etc. This bag can be helpful especially after a storm.

A Helpful Hint: To prolong the life of bags, remove the cleaner from pool before adding chemicals.

5. Sweep Hose

The Sweep Hose is provided to help keep the bottom and sides of your pool clean. The Sweep Hose is warranted free of defects when shipped from the factory, and is considered a wear item.

6. Debris Valve

This valve is located under the Debris Bag, it is designed to keep the debris inside the bag. It functions like a check valve to allow the debris to only enter through the bag one way. Replacement is needed when valve begins to stiffen.

E. Back Washing the Pool Filter

Always disconnect the Legend® from the pool wall before cleaning or back washing the pool filter. After cleaning or back washing, let the pool filtration system run for a minimum of five minutes to flush out the return lines before reconnecting the Legend®.

F. Storage and Winterizing

Never leave or store the Legend® in direct sunlight. When storing the Legend® for the winter, be sure to drain all the water from it. This is important since freeze damage is not covered under the warranty. Also, remove the Wall Fitting.

G. Accessories

1. Sweep Hose Weight

If the sweep hose tends to break the surface of the water therefore squirting nearby windows or innocent bystanders, a weight can be installed to the end of the sweep hose.

(Part # for Hose Weight is EH09C)

G. Accessories (cont.)

2. Leaf Bag

(See previous page)

3. Step Adapter

This adapter is designed for vinyl liner pools that have steps installed in such a way that the unit may not climb and remains stationary until the Back-up Valve comes on. The adapter acts as a bumper to turn the cleaner away from the steps and continue on cleaning your pool.

It's easy to install: Simply slide the Step Adapter into one of the slots (either side) located in the front of your Legend® and adjust to the appropriate height. (Part # for Step Adapter is EU13)

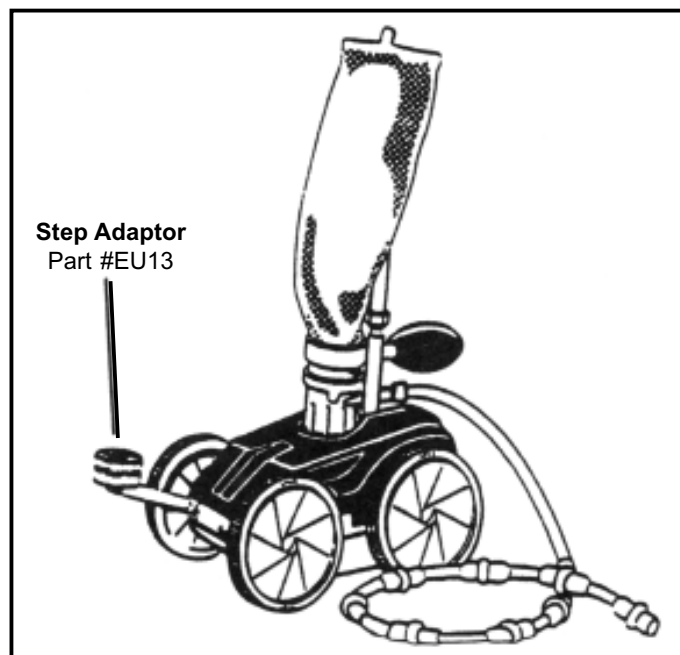

4. New Legend® suction Cup Tires

Designed to climb in problem areas, fiberglass, tile and smooth surfaces. For other applications, please contact our Technical Service Department at 1-800-831-7133.

(Part # for Suction Cup Tires is LC6LSA)



IV. TROUBLESHOOTING AND PERFORMANCE TIPS

To insure the best performance from your cleaner, follow the troubleshooting guide listed below.

A. PROBLEMS & SOLUTIONS

Problem: Legend® doesn't move or moves sluggishly or hangs up on steps.

- Solution:**
1. Be sure filter pump and booster pump are on and working properly. (You may need to clean your pool filter system).
 2. Check the Wall Fitting screen for debris and rinse clean.
 3. Check wheel RPM, (see page 8).
 4. Determine if the Back-Up Valve is cycling. (Hold the valve out of the water and the jet should come on for approx. 30 seconds and shut off for approx. 3 minutes and 30 seconds.)
 5. Check all the Hose connections and Swivels for leaks that can cause loss of water pressure.
 6. Check debris that may be jammed in the gear teeth on one of the front drive wheels. Gently rotate the front wheels backward to dislodge debris.

Problem: Legend® falling over or lying on its side.

- Solution:**
1. This usually indicates the bag needs to be emptied.
 2. Check to see if the ballast float (EA20) is leaking by checking if there is water inside. Unscrew by pulling back while turning counter-clockwise. When it comes off, shake it and listen for water in the float.

Problem: Legend® will not back up.

- Solution:**
1. Determine if the Back-Up Valve is cycling. (Hold the valve out of the water and the jet should come on for approx. 30 seconds, and shut off for approx. 3 minutes and 30 seconds).
 2. Check the wheel RPM, (see page 8).
 3. Empty the debris bag if full or half full.

Problem: Legend® will not climb.

- Solution:**
1. Even if your pool doesn't show algae you still need to brush the sides of the pool wall.
 2. Check the wheel RPM, (see page 8).
 3. Reposition the Thrust Jet. Loosen the two screws to adjust the Thrust Jet, (see page 7).

A Reminder: The climbing ability of the Legend® is dependent on the pool's shape and available water pressure. It will climb better in pools without sharp angles or curves in the transition from the pool floor to the pool wall.

Problem: Hoses tangling.

- Solution:**
1. Check the length of the Feed Hose, they may be too long, (see pages 3-5).
 2. Check to see that the Feed Hose is floating on top of surface. Check hose floats for even spacing.
 3. Twist the Hose Swivels to see if they spin freely and replace any that will not.
 4. Lay out the Feed Hose straight in the full sun to remove any memory.

Problem: Sweep Hose is sucked into the cleaner.

- Solution:**
1. Adjust the Sweep Hose using the Adjustment Screw located on the bottom of the Swivel Mast and just below the upper Thrust Jet. Turn Adjustment Screw clockwise until the Sweep Hose is in a gentle sweeping motion.

Problem: Booster Pump very noisy.

- Solution:**
1. Make sure Wall Fitting is mounted in pool wall correctly.
 2. Make sure Pool Filtration system is working properly.
 3. Contact your local Pool Professional -possible Booster Pump problem.

Problem: Sweep Hose breaks water surface and sprays nearby windows, patio decks and bystanders.

- Solution:**
1. Adjust Sweep Hose to a gentle sweeping motion.
 3. Add optional Sweep Hose weight, (see page 10).

LEGEND® PARTS LIST

Diagram #	Part #	Description	Quantity
1	LLU5N	Top Cover	1
2	LLU145N	Main Frame	1
3	EU10N	Bottom Cover	1
4	LLU6	Feed Mast w/O-Ring	1
5	EC86	Turbine Drive Shaft - Complete	1
6	EC83	Turbine Spacers	2
7	EC80	Turbine Bearings	2
8	EA40	Turbine Shaft Shield	1
9	EC110	Turbine Cover w/Elbows	1
10	EX120	Turbine Cover Hose - 9" length	1
11	EC120	Venturi Jet - Hose - 7¾" length	1
12	EB5L	Sweep Hose - Complete	1
13	EB10	Sweep Hose - Wear Ring	9
14	EB25	Sweep Hose - Jet w/Collar	1
15	EB20	Sweep Hose - Adjustment Screw	1
16	EA20	Ballast Float	1
17	EH07	Sweep Hose - Hose Sleeve	17
18	EU15	Coarse Mesh Bag (Optional)	1
19	EU16	Fine Mesh Bag	1
20	EU9	Debris Valve	1
21	EU7	O-Ring for Feed Mast	1
22	E18	O-Ring for Thrust Jet	1
23	EC130	Thrust Jet	1
24	EC135	Thrust Jet - Plate	1
25	EC65	Axle - Large Wheels	4
26	EC70	Axle Plate	4
27	EC45	Axle - Lock Washer	8
28	EC6L	Wheel w/out Bearings	4
29	EC60	Wheel Bearings Only	8
30	E10	Back-Up Valve	1
31	EC55	Wheel Screw - Plastic	4
32	LLC1	Wheel - Rubber Tire	4
33	EB15	Hose Clamp	5
34	EC40	Screw	8

LEGEND® PARTS LIST

Part #	Diagram #	Description	Quantity
LLD50	35	Feed Hose - clear soft - 10'	1
ED10P	36	Float - Feed Hose	10
LLD45	37	Feed Hose - white - 10'	2
ED05	38	Swivel - Feed Hose	2
LLU1	39	Adapter Hose - white - 8-1/2"	1
ED15	40	Mender Nut - plastic - feed hose	8
EW22	41	Wall Fitting	1
E24	42	Screen - Wall Fitting	1
E23	43	Quick Disconnect Adapter	1
EC64	44	Wheel - Plastic Washer	4
EH09C	45	Sweep Hose Weight	1
EG15	46	Gears - for Back-Up Valve	1
EC131	47	Thrust Jet Repair Kit includes: LLC130, LLC153, LLC140	1
EA30	48	Screw for LLA40 and LLC110	5
EU76	49	Axle Bolt	8
EU147	50	Snap Fit Vac Tube Posts	2
EU79	51	Nut & Bolt - Feed Mast to Vac Tube	1
LLU8	52	Venturi Jet	2
EU80	53	Hex Screw - Cover to Frame	2
LLU82	Not Shown	Snap Fittings	2

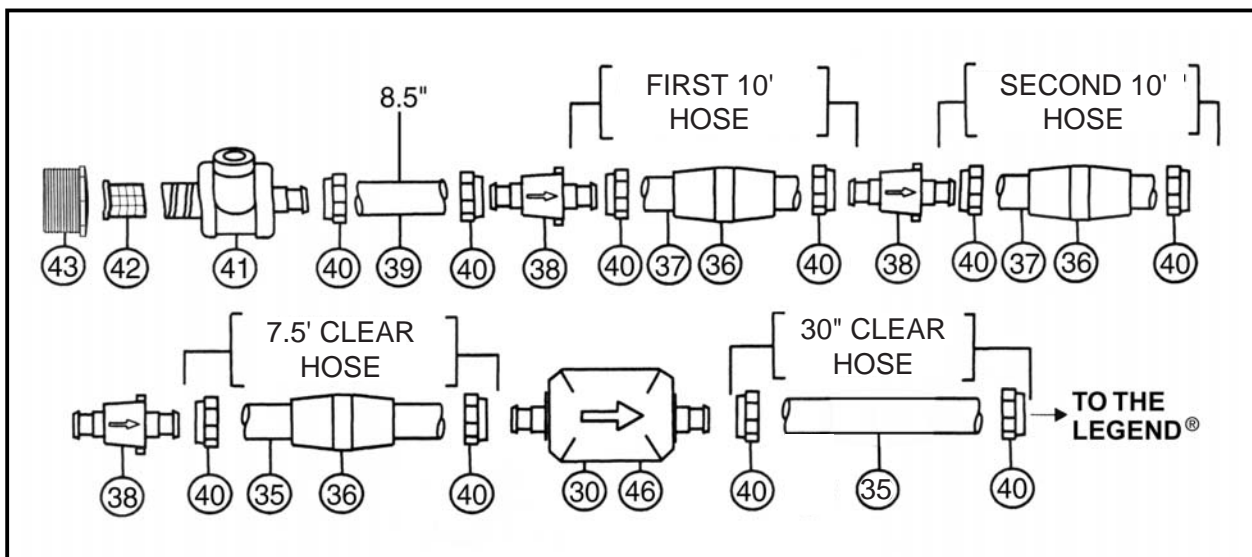

LEGEND® EXPLODED VIEW

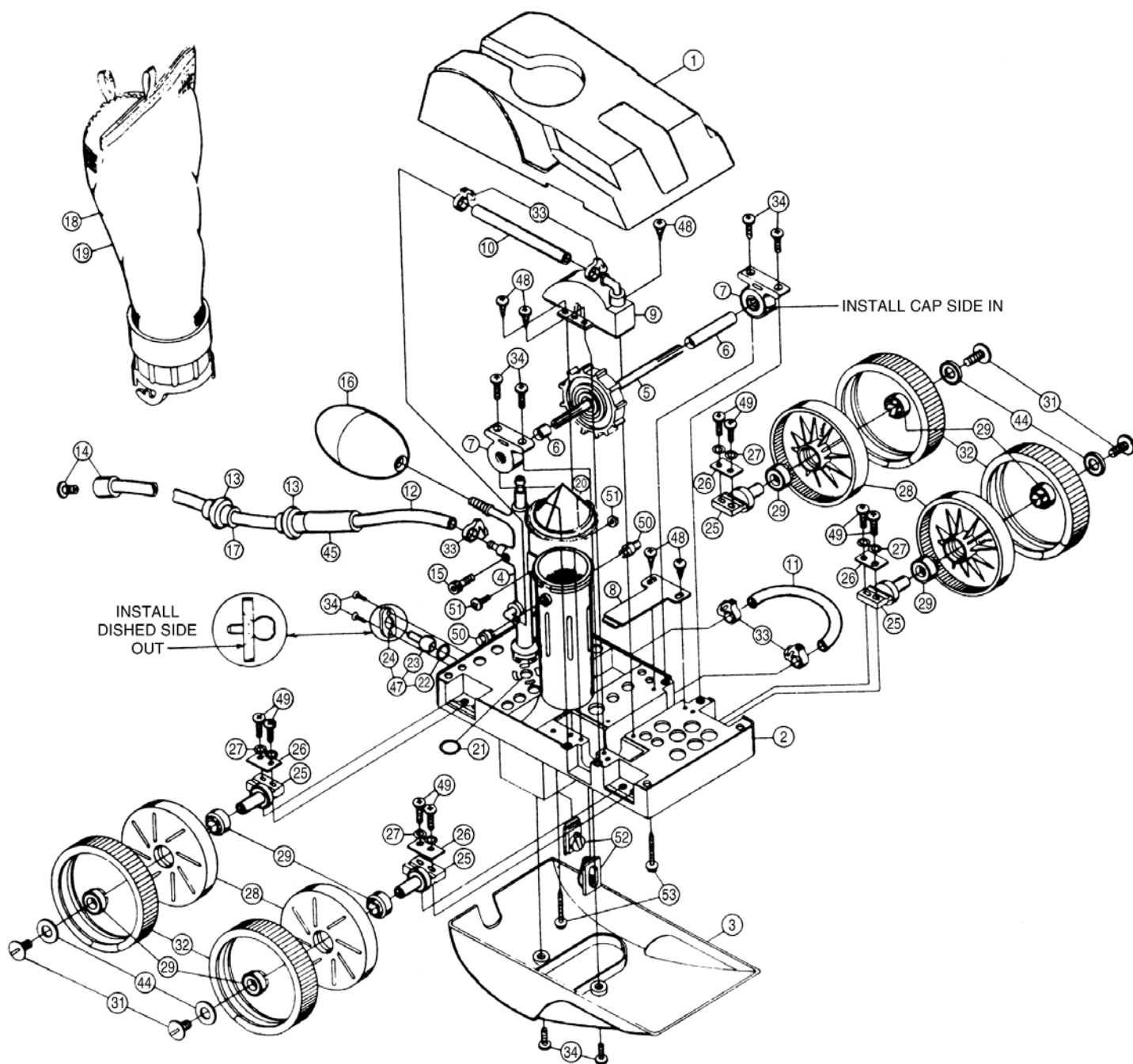

SAVE THESE INSTRUCTIONS.

